

Description

The F1478 is a high gain, two-stage RF Amplifier designed to operate within the 1800MHz to 5000MHz frequency range. Using a single 5V power supply and only 140mA of I_{CC} , the F1478 provides 29.6dB of Gain and 1.8dB of Noise Figure with up to +37.3dBm OIP3 and 25.5dBm OP1dB at 3550MHz.

The F1478 is packaged in a 3×3 mm, 16-QFN, with matched 50Ω input and output impedances for ease of integration into the signal path.

Competitive Advantage

- Combines a two-stage RF amplifier in a single, compact 3×3 mm QFN package
- Excellent performance over exceptionally wide bandwidths
- Single device provides adjustable linearity versus current via an external resistor

Typical Applications

- 4G / 5G Cellular Basestations
- Multi-mode, Multi-carrier Transmitters
- Active Antenna Systems

Features

- RF Range: 1800MHz to 5000MHz
- 29.6dB Typical Gain at 3550MHz
- 1.8dB NF at 3550MHz
- Adjustable OIP3 Performance
 - +37.3dBm OIP3 at 3550MHz and 140mA of bias current
 - +33.8dBm OIP3 at 3550MHz and 100mA of bias current
- Adjustable OP1dB Performance
 - +25.5dBm OP1dB at 3550MHz and 140mA of bias current
 - +24.5dBm OP1dB at 3550MHz and 100mA of bias current
- 5V Power Supply
- Adjustable I_{CC} ranging from 80mA to 160mA
- 50Ω Single-ended Input and Output Impedances
- 1.8V Logic Compatible Standby Mode for Power Savings
- Operating Temperature (T_{EPAD}) Range: -40°C to $+115^{\circ}\text{C}$
- 3×3 mm 16-QFN package

Block Diagram

Figure 1. Block Diagram

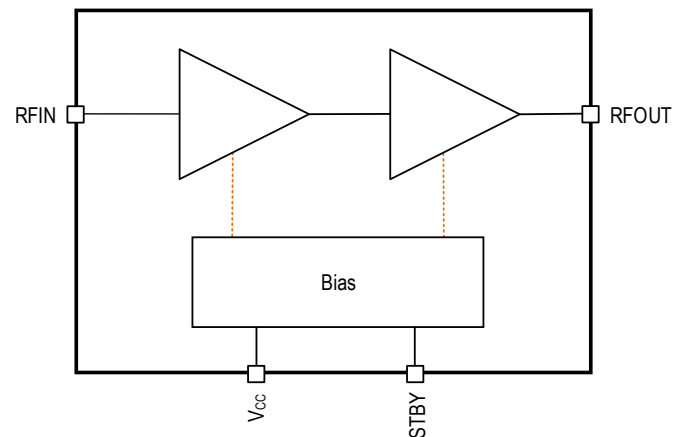

Ordering Information

Orderable Part Number	Package	MSL Rating	Shipping Packaging	Temperature
F1478NLGA	3 × 3 × 0.9 mm QFN	MSL 1	Tray	-40° to +115°C
F1478NLGA8	3 × 3 × 0.9 mm QFN	MSL 1	Tape and Reel	-40° to +115°C
F1478EVBA	Evaluation Board			



Corporate Headquarters

6024 Silver Creek Valley Road
 San Jose, CA 95138
www.IDT.com

Sales

1-800-345-7015 or 408-284-8200
 Fax: 408-284-2775
www.IDT.com/go/sales

Tech Support

www.IDT.com/go/support

DISCLAIMER Integrated Device Technology, Inc. (IDT) and its affiliated companies (herein referred to as "IDT") reserve the right to modify the products and/or specifications described herein at any time, without notice, at IDT's sole discretion. Performance specifications and operating parameters of the described products are determined in an independent state and are not guaranteed to perform the same way when installed in customer products. The information contained herein is provided without representation or warranty of any kind, whether express or implied, including, but not limited to, the suitability of IDT's products for any particular purpose, an implied warranty of merchantability, or non-infringement of the intellectual property rights of others. This document is presented only as a guide and does not convey any license under intellectual property rights of IDT or any third parties.

IDT's products are not intended for use in applications involving extreme environmental conditions or in life support systems or similar devices where the failure or malfunction of an IDT product can be reasonably expected to significantly affect the health or safety of users. Anyone using an IDT product in such a manner does so at their own risk, absent an express, written agreement by IDT.

Integrated Device Technology, IDT and the IDT logo are trademarks or registered trademarks of IDT and its subsidiaries in the United States and other countries. Other trademarks used herein are the property of IDT or their respective third party owners. For datasheet type definitions and a glossary of common terms, visit www.idt.com/go/glossary. All contents of this document are copyright of Integrated Device Technology, Inc. All rights reserved.